

■DESCRIPTION

The WB-2000-2 (containing 2 pieces) is an AA nickel-metal hydride (Ni-MH) rechargeable battery pack designed for exclusive use with the WM-5225 and WM-5265 Wireless Microphones, WM-5325 Wireless Transmitter, and WT-5100 Portable Receiver

■SPECIFICATIONS

Nominal Voltage	1.2 V DC
Capacity	1900 mAh (rated), 2000 mAh (typical)
Operating Temperature	0 °C to +40 °C (32 °F to 104 °F)
Operating Humidity	30 % to 85 %RH (no condensation)
Dimensions	∅14.2 × 50.2 mm (∅0.56" × 1.98")
Weight	30 g (1.06 oz) (per piece)

■APPEARANCE

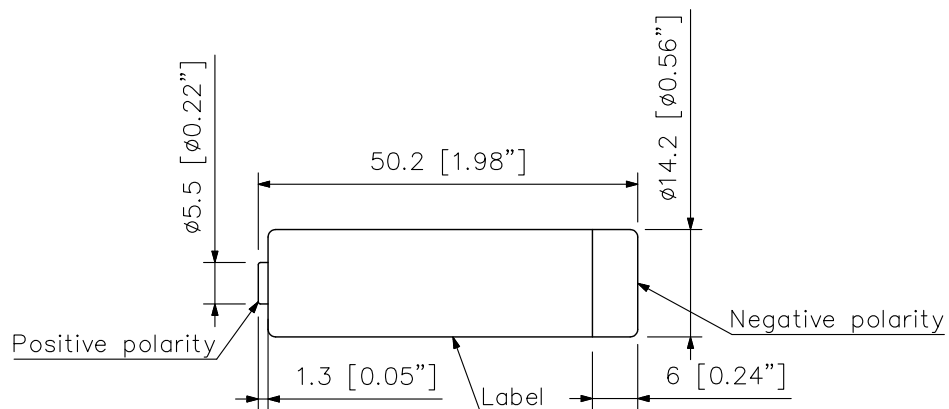

Notes

1. When using the WB-2000-2 for the first time, be sure to charge it.
2. Insert the WB-2000-2 into the WM-5225 or WM-5265 Wireless Microphone, WM-5325 Wireless Transmitter, or WT-5100 Portable Receiver, then charge it using the dedicated BC-5000 Series Battery Charger.